

# INDIAN INSTITUTE OF TECHNOLOGY, KHARAGPUR KSHITIJ 2016

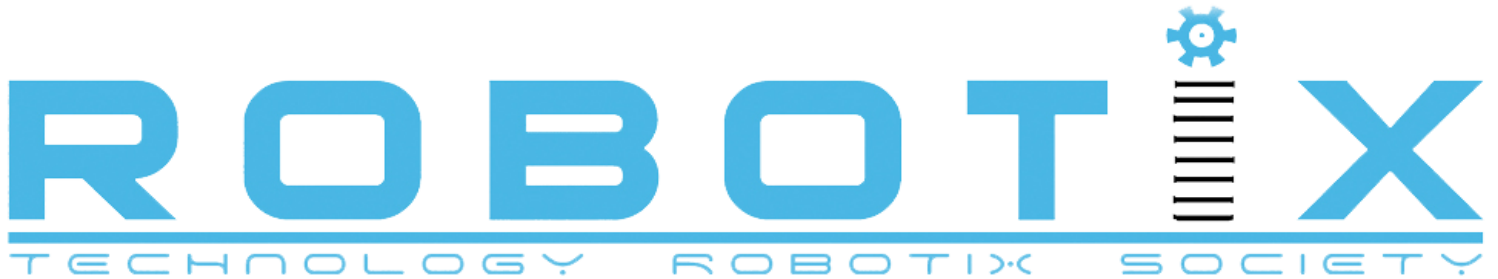

## Summit

## Manual Robotics

USP: Stair climbing

### Introduction:

Stair Climbing has always been one area that roboticists have wanted to conquer, considering the ease with which humans do it and the same degree of technical difficulties robots face while doing so. Adding a competitive edge to an already challenging research area, manual event Summit brings an opportunity for the best innovators across the region to aid the design and development of such mechanisms.

**Problem Statement:**

Build a manually controlled robot capable of climbing staircases, whilst picking, storing and placing objects on its way.

**Task:**

The robot has to climb stairs of uniform height to reach a higher level platform. It should collect and store the blocks, and carry them up the stairs. Then, deposit the objects to the respective deposit zones based on their colour.

**Round 1:**

**Task:**

- There are staircases of varying number of stairs.
- Height, length and width of the stairs are **8 cm, 60 cm and 15 cm** respectively  
\*The height of the staircase may vary from  $\pm 1$  cm.
- The bot has to climb stairs avoiding bumping into the obstruction.
- It has to avoid bumping into the obstruction and the surrounding wall while taking a 90 degree turn.
- At every point in the arena there will be at least a space of **40cm x 40cm** for the robot to manoeuvre.
- Maximum time of the run is **3 minutes**.
- Maximum no. of time outs allowed is **1**(1 minute).
- Only one restart is allowed and that too in case of a technical fault.

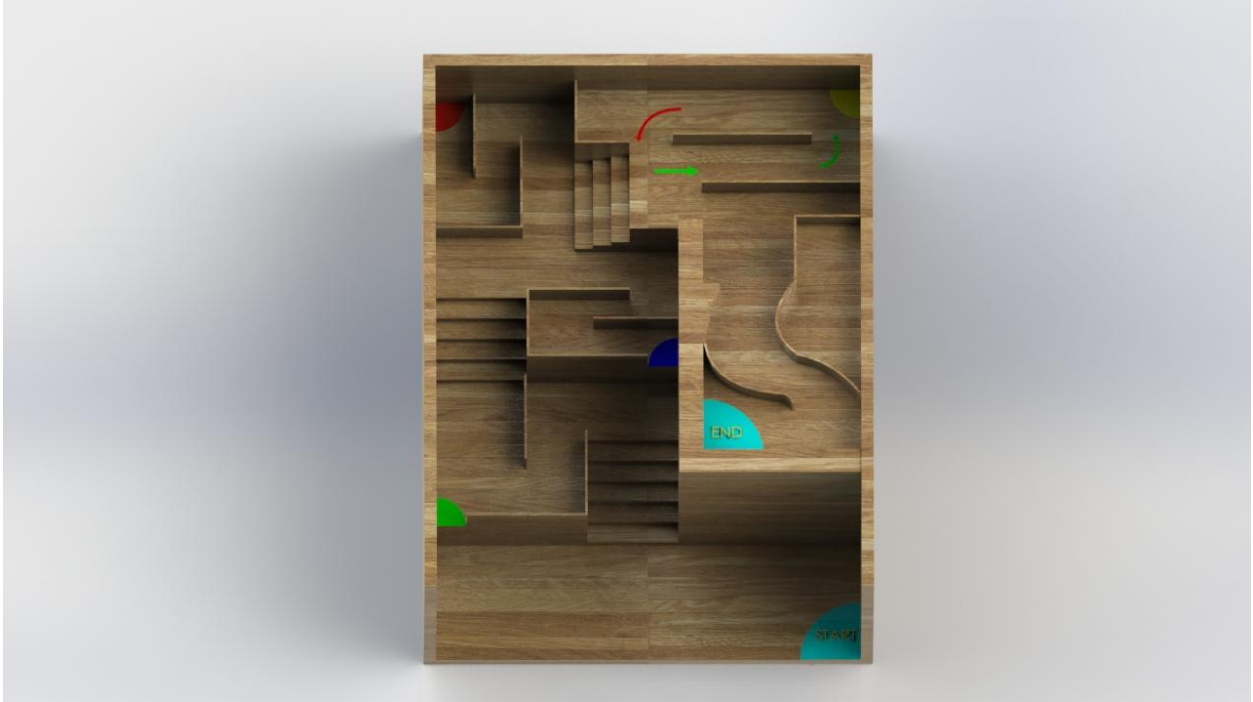

TOP VIEW



FRONT VIEW

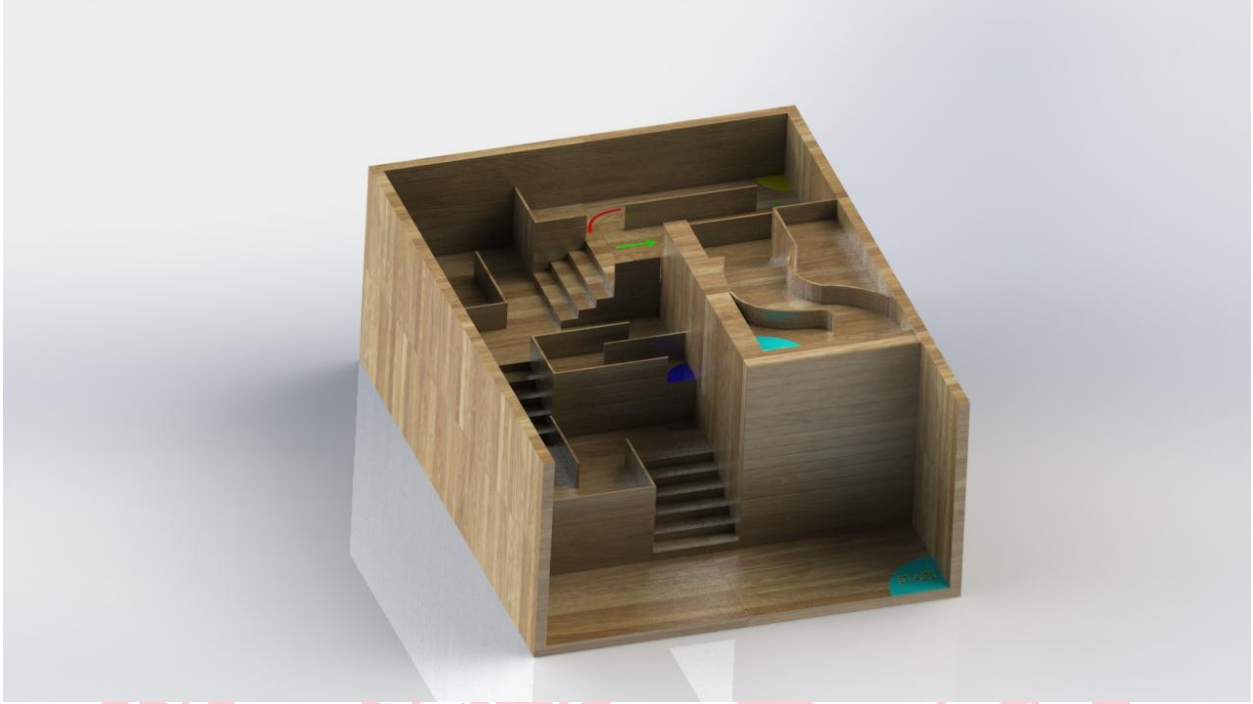

**ISOMETRIC VIEW**



**REAR VIEW**

## Round 2:

### Task:

- The dimension of each stair is **60cm x 15cm x 8cm (l\*b\*h)**.  
\*The height of stair might vary from  $\pm 1\text{cm}$ .
- The robot has to climb up the staircases using a suitable mechanism.
- It has to pick up objects placed along the way and **store them (optional)**.
- It has to deposit the stored objects at certain marked zones on the arena.
- The object have to be placed according to the **colour codes**.
- After the all the blocks are placed the bot has to reach the end zone to finish the round.
- Maximum time: **5 minutes**.
- There are total six objects in the arena.
- Maximum number of Time-outs allowed :**2**(1 min)
- Restarts allowed: 1
- NOTE: Restarts will be given only for technical fault in the bot.

## Round 3:

### Task:

- Task would be announced at the time of event.

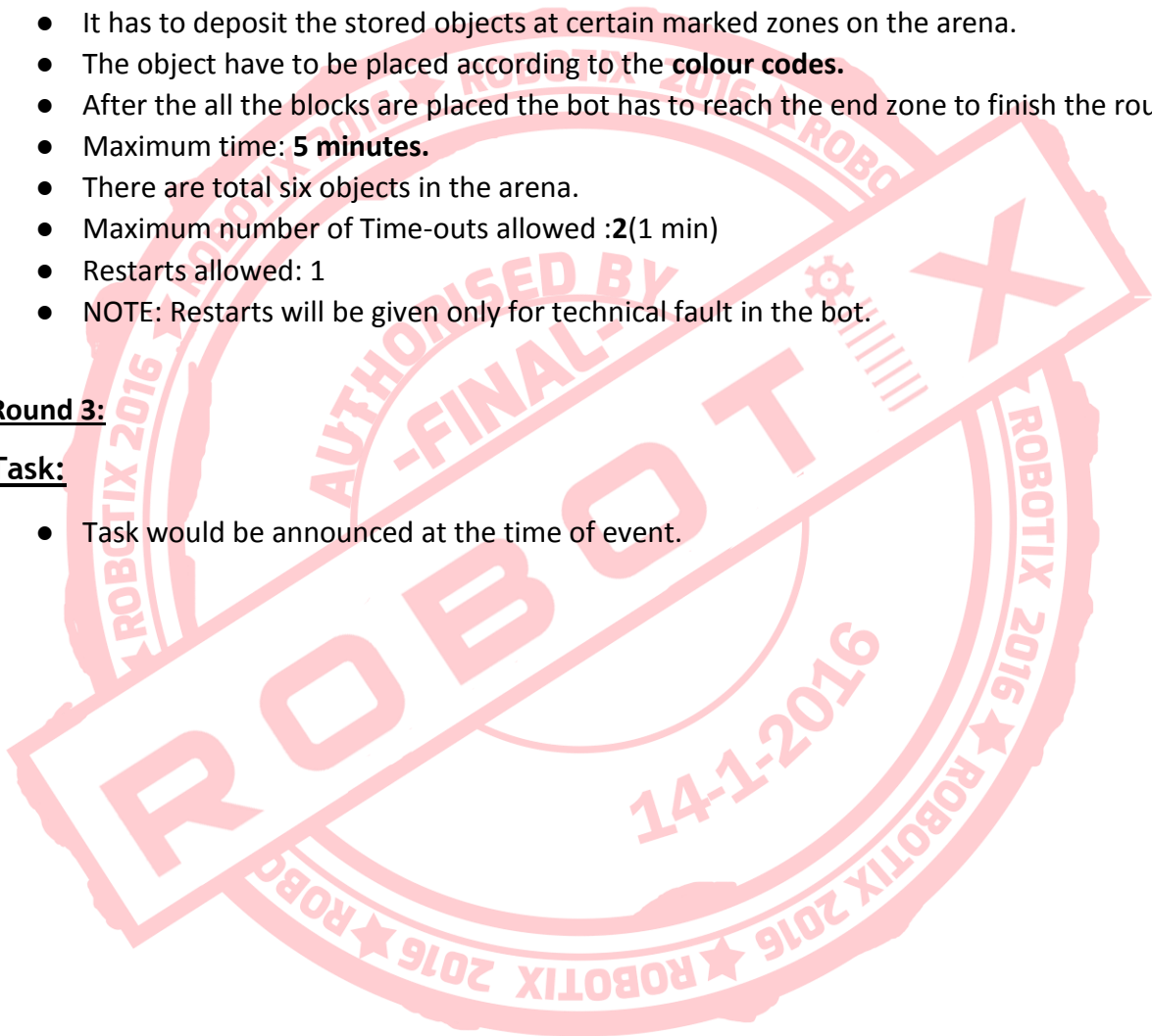

### TOP VIEW

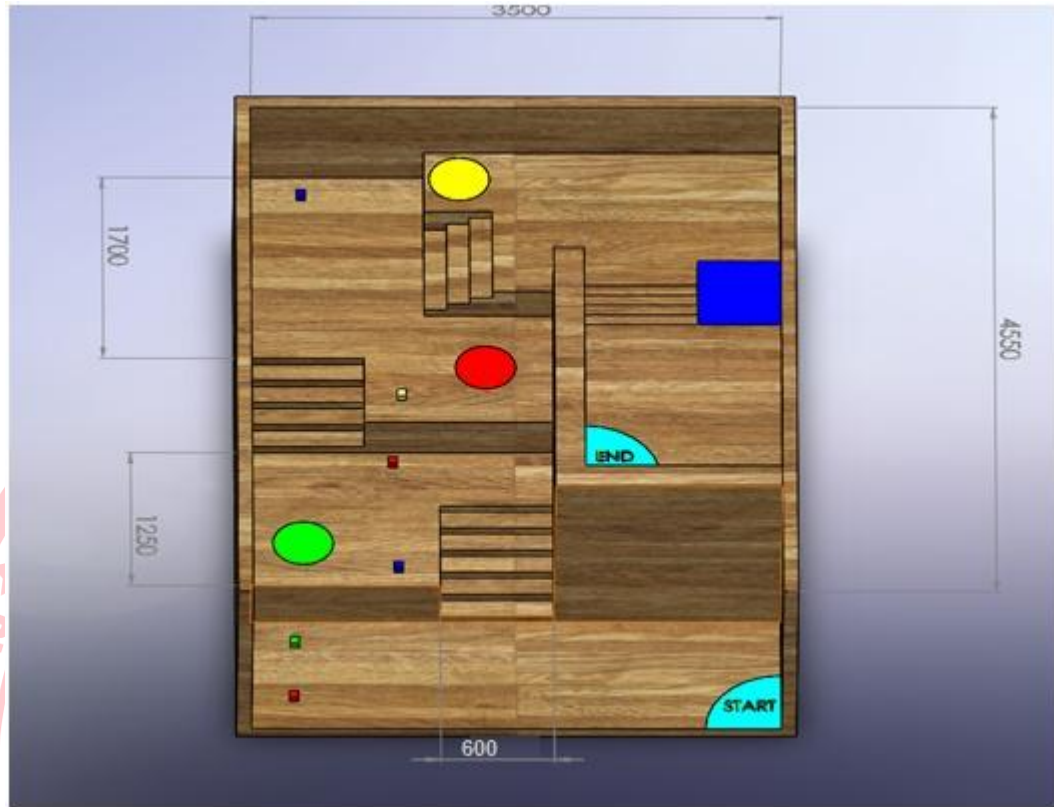

\*All dimensions are in cm.



**FRONT VIEW**

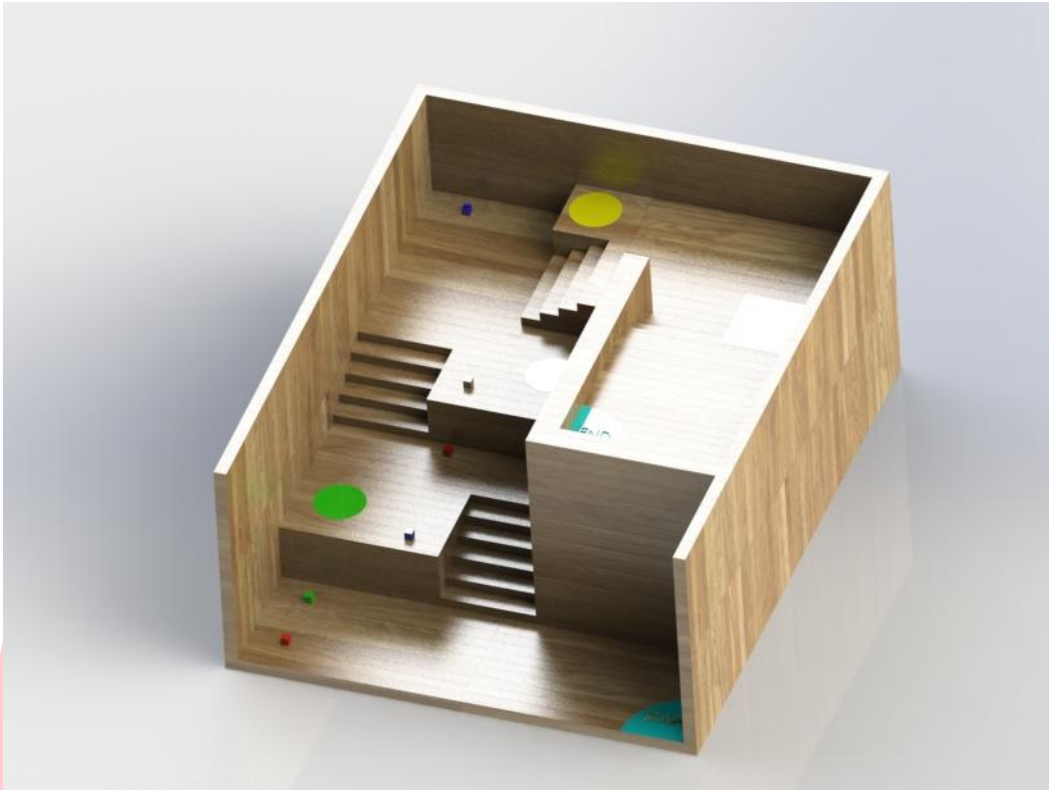

**ISOMETRIC VIEW**

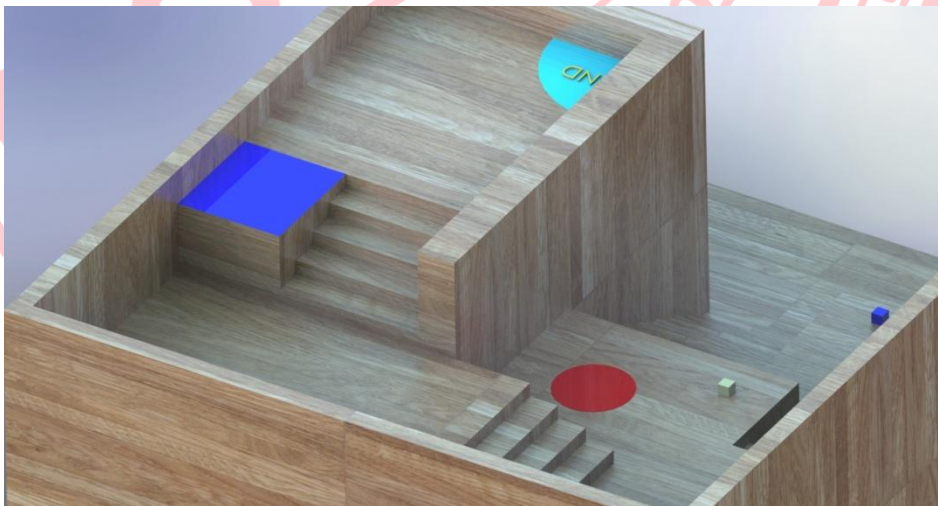

## Arena Dimensions:

### Round 1:

- In this round, the length, breadth and height of the arena is **4.5m X 3.5m** respectively.
- The dimension of each stair is **60cm x 15 cm x 8 cm** ( $l*b*h$ )  
\*The height of stair may vary from  $\pm 1$  cm.
- The dimension of each obstruction is **25cm**. The length varies throughout the arena.

### Round 2:

- In this round the dimensions of the arena is **4.55m x 3.5m** ( $l*b$ ).
- The dimension of each stair is **60cm x 15cm x 8cm** ( $l*b*h$ ).  
\*The height of stair might vary from  $\pm 1$ cm.
- The dimension of each object is **3.5cm x 3.5cm x 3.5cm**

### Stair Specification:

- There are staircases of **varying** number of stairs.
- Height, length and width of the stairs are **8 cm, 60 cm** and **15 cm** respectively  
\*The height of the staircase may vary from  $\pm 1$  cm.

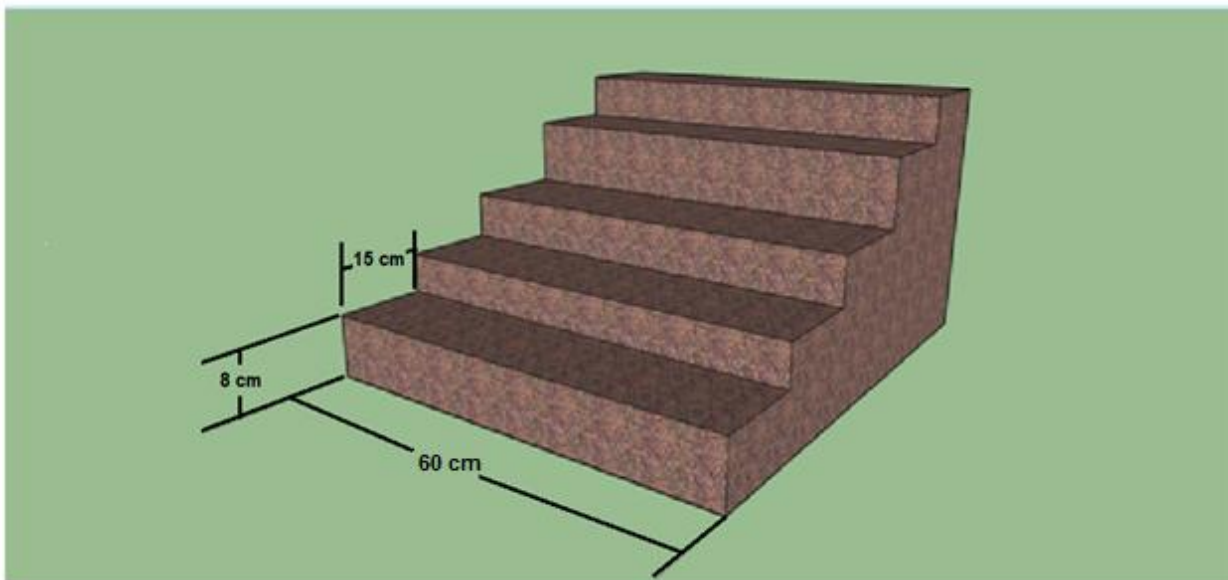

### Object Specification:

- These will be wooden cubes of dimension **3.5 cm \* 3.5 cm \* 3.5 cm** ( $l*b*h$ ).
- The upper surface of the object will be provided with a hook for the corresponding lifting mechanism.
- The weight of the object will be less than 90 g.



- Different objects will be coloured differently **based on their respective deposit zones.**

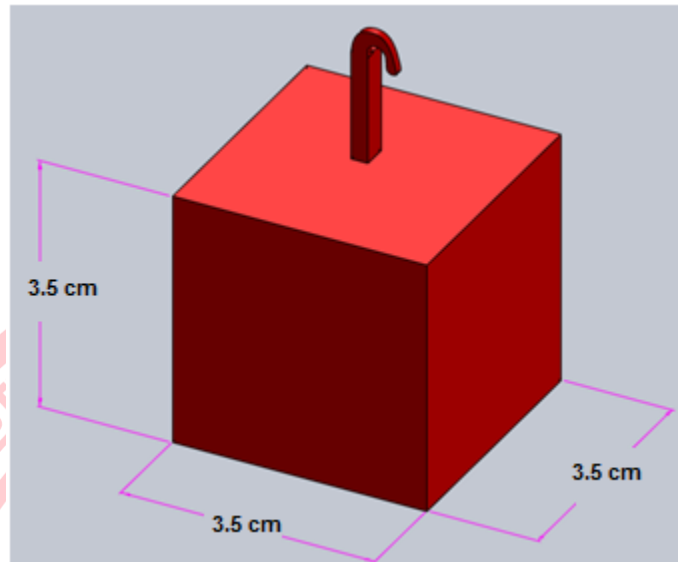

#### **Obstruction Specification:**

- There will be some obstructions of height **25cm**. Length of obstructions varies accordingly.
- It is **mandatory** for the bot to turn at these obstructions.

#### **Rules and Specifications:**

##### **General Rules:**

- All arena dimensions have a tolerance of 10%.
- Each team should have unique participants i.e. no two teams can have even a single participant common.
- The team members can be from different institutes or colleges.
- Teams qualifying the first round will go into the second round and those qualifying the second round will participate in the third round.
- The teams cannot touch their bots during the course of the run, unless timeout is taken.
- The right spirit of participation is expected from the participants.
- Maximum number of participants allowed per team: **4 people**.
- The participants will be provided with **220 Volts, 50 Hz** standard AC supply.
- Participants will have to arrange for any other power supply required for their robot.
- Teams cannot tinker with their bots during the run.
- LEGO kits or its spare parts or pre-made mechanical parts are not allowed. ([http://en.wikipedia.org/wiki/Lego\\_Mindstorms](http://en.wikipedia.org/wiki/Lego_Mindstorms))
- The decision of the Team Robotix will be final and binding.

- **The rules are subject to change.**

#### **Event Rules:**

- The robot can have any suitable mechanism to climb up the stairs without damaging the arena.
- In the second round the robot has to collect and store the blocks, and carry them up the stairs.
- It has to deposit the blocks to the respective deposit zones distinguished by their color.
- The arena will have some obstructions at each staircase landings, **enforcing 90-degree turns**. The bot has to manoeuvre around and climb.
- Points will be awarded for collecting and depositing the blocks at the end of the run.

**Collected Objects:** On the robot.

**Deposited Objects:** Blocks at the platform.

- The third round will be One-on-One whose arena will be disclosed during the event. No additional mechanism will be required for it.

#### **Robot Specification:**

- The robot must fit in a box of **30cm x 30cm x 30cm** with a tolerance of 10% in the dimensions of robot. No part/mechanism of/on the bot should exceed the given dimensions before the commencement of the event. However the dimensions can change during the course of the run.
- Dimensions of the arena are to be considered with a maximum tolerance of 10%.

#### **Scoring:**

#### **Rewards:**

- 75 points awarded for reaching a new floor (F)
- Time factor (t)
- 50 points awarded for reaching a destination point (D)
- 50 points will be awarded for picking up and storing a block (BP)
- 75 points awarded for placing the blocks in the **correct zone** (BD)

#### **Penalties:**

- 25 points deducted for bumping into the obstruction (B)
- 50 points will be deducted for each time out (T)
- 50 points deducted if the robot falls down the stairs (Q)

- 100 points will be deducted for each restart(1 allowed) ®
- 25 points deducted if the block falls from the robot (BF)

### Scoring:

- **Round 1:**  $75*(F) + t'(t)*\text{time remaining} + 50*(D) - 25*(B) - 50*(T) - 50*(Q) - 100*(R)$

**NOTE: Only 1 Time-out is allowed in Round 1**

- **Round 2:**  $75*(F) + t'(t)*\text{time left} + 50*(BP) + 75*(BD) - 25*(B) - 25*(BF) - 50*(T) - 50*(Q) - 100*(R)$

**NOTE: Only 2 Time-outs are allowed in Round 2**

### Tutorial & Resources:

Visit [website link](#) to check out the latest Event Updates.

Read our [tutorial](#) for Summit.

Join the [Event Facebook Group](#) for latest updates and doubt sessions.

### Contact:

For queries, contact our Event Heads:

**Apoorva Sharma**

(91) 9800105345

apoorva.sharma@robotix.in

**Rohan Lohia**

(91) 7872846690

rohan@robotix.in